

S SERIES Solar Collectors

Glazed Liquid Flat Plate Collectors

Technical Specifications

SRCC Certification # 100-2009-007A



Thermo Dynamics Ltd.

101 Frazee Avenue

Dartmouth, Nova Scotia

Canada, B3B-1Z4

Tel: (902) 468-1001 Fax: (902) 468-1002

Email: solarinfo@thermo-dynamics.com

www.thermo-dynamics.com

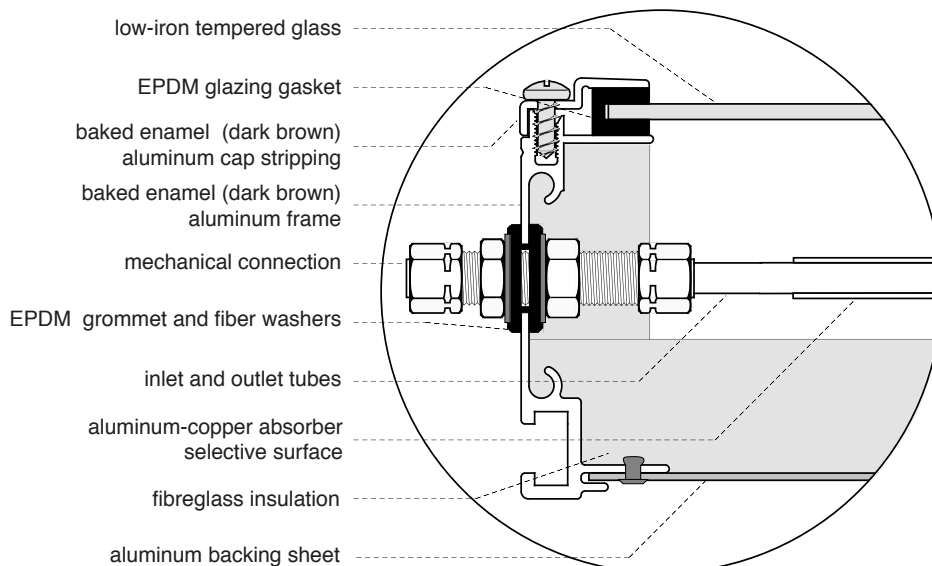
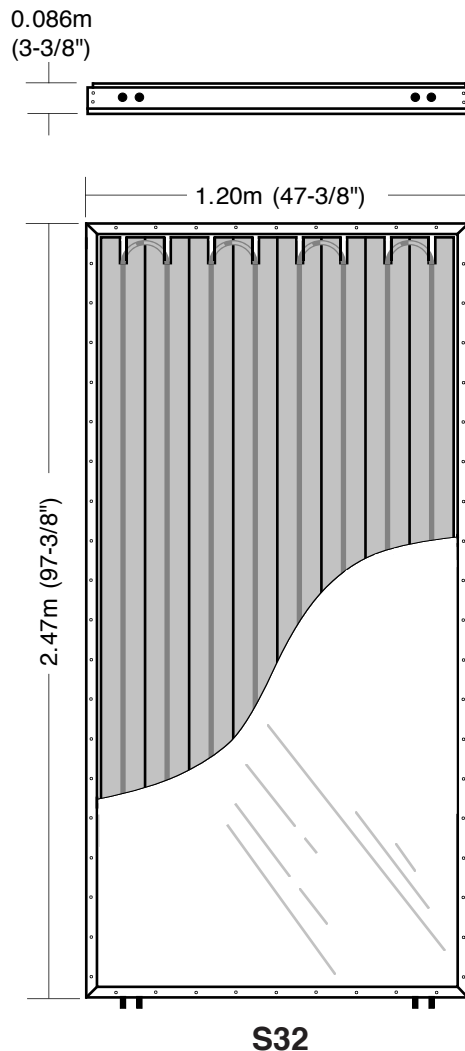

A. General Information

1.0 Product Description:

Thermo Dynamics S32 flat plate liquid collectors are single glazed with low-iron tempered glass. The absorber consists of a single serpentine aluminum fin with an integral copper tube, which is completely surrounded by the aluminum and metalurgically bonded together. The back and sides are insulated with a 25 mm (1") layer of compressed fiberglass. The collector frame is extruded aluminum with a baked-enamel finish, (dark brown). Collector mounting is by way of a sliding bolt-track. Flush and racked collector mounting formats are easily accommodated.

1.1 Options:

"A" collector with 4 external connections (inlet, outlet, bypass tube); "B" collector with 2 external connections (inlet, outlet); factory installed temperature sensor well; absorber coatings: selective paint surface.

1.2 Dimensions:

S32: 1.20 m x 2.47 m x 0.086 m
 47-3/8 in x 97-3/8 in x 3-3/8 in
 Gross area: 2.98 m² (32.1 ft²)
 Aperture area: 2.78 m² (30.0 ft²)
 Absorber area: 2.87 m² (30.9 ft²)
 Volume: 0.389 liter (0.086 IG)

Connections: 3/8" compression fittings

1.3 Weight:

Net: 43.5 kg (96 lbs)
 Shipping: 64 kg (140 lb)
 (includes wooden crate)

2.0 Product Use

2.1 Product Applications:

Residential domestic hot water, small commercial and industrial process hot water.

2.2 Geographic and Climatic Limitations:

None.

2.3 Certifications:

Solar Rating & Certification Corporation (SRCC) #100-2009-007A.
<http://www.solar-rating.org>

Listed by Natural Resources Canada (NRCAN) as an acceptable solar collector.
<http://www.ecoaction.gc.ca>

S SERIES Solar Collectors

Glazed Liquid Flat Plate Collectors

Technical Specifications

SRCC Certification # 100-2009-007A

3.0 Manufacturer's Experience

3.1 Background:

Thermo Dynamics Ltd. (TDL) is a Canadian company engaged in the research, development, production, distribution and installation of solar thermal equipment. The company has been involved in the solar thermal industry since 1981 and operates from its head office and factory in Dartmouth, Nova Scotia, Canada, the sister city of Halifax situated on the Atlantic coast. The company's specialization is the glazed liquid-flat-plate (LFP) collectors with metal absorbers. TDL is a fully integrated solar thermal company with the ability to convert raw aluminum and copper into a high technology solar water heating system.

Thermo Dynamics Ltd., as a world leader in solar technology, manufactures and markets solar heating equipment from complete systems to basic selective surface components for O.E.M.'s licensees, dealers and distributors through out North America, Europe, Africa, New Zealand, as well as 10 other countries around the world.

3.2 Production:

3000 m² (32,300 ft²) per year for S32 collectors

3.3 Projects:

Bedford, S-2000
Bedford, Nova Scotia, Canada
Collector number and type: 120 - S32
Total collector area: 360 m² (3875 ft²)
Residential application, with 2 - S32 per home.

Guelph 2000
Guelph, Ontario, Canada
Collector number and type: 200 - S32 collectors
Total collector area: 600 m² (6460 ft²)
Residential application, with 2 - S32 per home

Switzerland
To date: 900 S32 solar collectors.
2700 m² (29,062 ft²)

Thermo Dynamics Ltd. has installed thousands of solar residential domestic hot water systems.

B. Glazing System

1.0 General Description:

Glazing is a 3.2 mm (1/8") single sheet of low-iron tempered glass with an EPDM rubber seal around the edges. Glazing is secured by an aluminum capping fastened by stainless steel screws around the perimeter.

1.1 Trade Names:

Solite

1.2 Chemical Composition:

Iron oxide content of 0.03%

1.3 Physical Treatment:

All glazing is tempered with swiped edges and has a shallow stipple pattern to reduce specular reflectance.

1.4 Thickness:

3.18 mm (1/8")

1.5 Spacing:

Glazing to absorber: 20 to 25 mm (3/4" to 1")

1.6 Weight:

7.8 kg/m² (1.6 lb/ft²)

1.7 Appearance:

Translucent; the inner surface is embossed with a stipple pattern which produces a frosted effect.

2.0 Optical Performance

2.1 Spectral Transmittance:

Visible light 89.8% ASTM E424-71A
Ultra violet light 51% ISO 9050
Solar light/energy 89.5% ASTM E424-71A

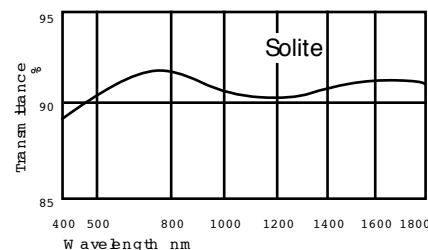

2.2 Energy Transmission:

Solar spectrum (0-3 micrometres)
S32: 89.5%
Infrared spectrum (>3 micrometres)
No data available

2.3 Refractive Index:

1.525

3.0 Structural Performance

3.1 Tensile Strength:

Design Pressure is 2.87 kPa (.416 psi) for 1/8 inch glass with a design factor of 2.5. Tensile strength is 152 MPa (22,000 psi) with a 2.5 safety factor.

3.2 Impact Resistance:

Glazing can withstand 542J (400 ft-lb) soft-body impact, 3 to 5 times stronger than annealed glass.

3.3 Uniform Load Resistance:

Uniform load testing was conducted at the National Solar Test Facility in June 2008 as part of CAN/CSA-F378-87, "Solar Collectors".

Positive load: 1.5 kPa (0.22 psi)

Negative load: 0.5 kPa (0.07 psi)

Negative load: 2.0 kPa (0.29 psi)

In that order

4.0 Thermal Performance

4.1 Coefficient of Thermal Expansion:

$89.9 \times 10^{-7} \text{ } ^\circ\text{C}^{-1}$ ($49.9 \times 10^{-7} \text{ } ^\circ\text{F}^{-1}$)

4.2 Operating Temperature Range:

Min: below -46°C (-51°F); max: 260°C (500°F)

4.3 Thermal Conductivity:

No data available

5.0 Fire Behavior:

Non-combustible. Does not produce toxic fumes in a fire situation.

6.0 Durability:

Glass is chemically inert to most chemical solvents and staining agents, and is resistant to surface weathering, ultraviolet and thermal degradation, and moisture damage.

S SERIES Solar Collectors

Glazed Liquid Flat Plate Collectors

Technical Specifications

SRCC Certification # 100-2009-007A



Thermo Dynamics Ltd.

101 Frazee Avenue

Dartmouth, Nova Scotia

Canada, B3B-1Z4

Tel: (902) 468-1001 Fax: (902) 468-1002

Email: solarinfo@thermo-dynamics.com

www.thermo-dynamics.com

C. Absorber System

1.0 General Description:

The absorber consists of eight aluminum fins arranged in a serpentine fashion with integral copper waterway tubes, which are bonded to and completely surrounded by the aluminum by means of a high pressure cold rolling process. The absorber coating is selective black paint. The absorber is fabricated from a single, continuous fin, with only 2 soldered joints at the absorber inlet and outlet connections.

1.1 Generic/Trade Names:

Absorber: "MICRO-FLO®"
Absorber fins: "Sunstrip™"
Tubes: copper
Headers: None
Coating: selective black paint
Solder: 95/5 tin antimony

1.2 Chemical Composition:

Absorber fins: aluminum (AA 1350/0 alloy)
Tubes: copper (CDA 1220/0 alloy)
Headers: None
Coating: selective black paint
Solder: no data available

1.3 Physical Treatment:

None.

1.4 Dimensions:

Tube diameter: rhombic shape with an open area of about 25.6 mm² (0.039 in²)
Tube spacing: 143 mm (5.63")
Absorber thickness: 0.5 mm (0.02")
Coating thickness: no data available.

2.0 Optical Performance

2.1 Absorptivity of Solar Radiation:

Painted surface: $\alpha = 95\%$

2.2 Emissivity of Infrared Radiation:

Painted surface: $\epsilon = 25\%$

3.0 Thermal Performance

3.1 Thermal Transfer:

Good thermal transfer due to the high conductivity of aluminum and the bond between the aluminum fins and copper tubes.

3.2 Coefficient of Thermal Expansion:

Fin tubes: $22 \times 10^{-6} \text{ } 1/^{\circ}\text{C}$ ($12.2 \times 10^{-6} \text{ } 1/^{\circ}\text{F}$)

To allow for thermal expansion, the absorber is free to float within the collector container. EPDM gaskets prevent contact between the copper tubes and the aluminum container.

3.3 Thermal Capacity of Absorber System:

No data available.

3.4 Operating Temperature Range:

Absorber: max. 160°C (320°F)
Tubes: max. 160°C (320°F)
Solder: min. -50°C (-58°F); max. 160°C (320°F)
Coating: max. 160°C (320°F)

4.0 Exposure Test:

The collector has completed a 30-day outdoor no-flow exposure test at The National Solar Test Facility (NSTF), Mississauga, Canada, June 2008. The test was in accordance to CAN/CSA F378-87. The test includes a preconditioning rain penetration test, 30 days exposure with a minimum of 17 MJ (16 MBtu) of incident energy per square metre of collector surface area, and a cold fill (thermal shock) test. There was no sign of degradation or loss in performance.

5.0 Durability:

The absorber and the selective surface are not affected by normal aqueous solutions. Stagnation testing has shown no thermal degradation.

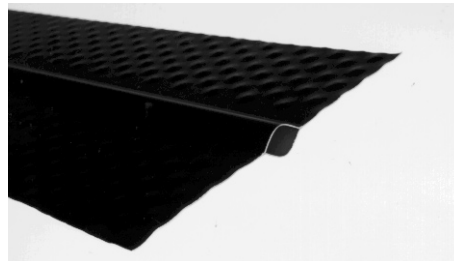

Sunstrip™ solar fin
Aluminum strip metallurgically bonded to a copper tube.

SS146/8:

- 143 mm wide
- 8 mm copper tube
- selective surface

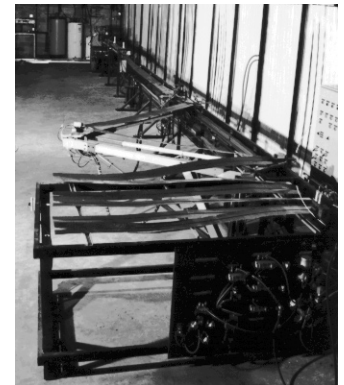
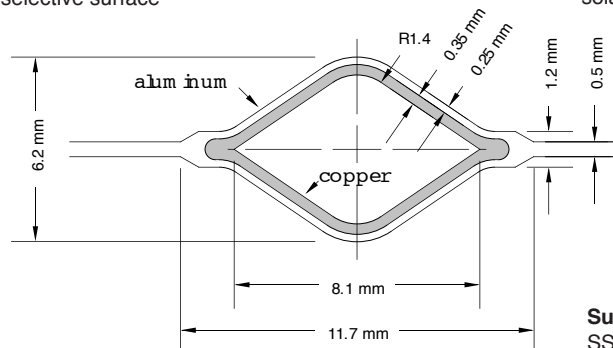

Sunstrip™ Fakir:

Operation punches and bends the solar fin into a serpentine

Sunstrip™ solar fin cross section
SS146/8
Scale: 4:1 mm

S SERIES Solar Collectors

Glazed Liquid Flat Plate Collectors

Technical Specifications

SRCC Certification # 100-2009-007A

D. Insulation

1.0 General Description:

Collectors are insulated around the sides and back with fiberglass board. Complies with ASTM-C-612 Classes 1 and 2.

1.1 Trade Names:

Sides: Fiberglas AF530
Back: Fiberglas AF530

1.2 Chemical Composition:

Fibrous glass bonded by a thermosetting resin. Inorganic, will not rot.

1.3 Density:

48 kg/m³ (3.0 lb/ft³)

1.4 Thickness:

Side: 25 mm (1")
Back: 25 mm (1")

2.0 Thermal Performance

2.1 Thermal Conductivity:

0.036 W/m·°C (0.25 Btu·in/hr·ft²·°F) at 24°C (75°F)

2.2 Thermal Resistance:

RSI 0.7 °C·m²/W (R 4 °F·ft²·hr/Btu) at 24°C (75°F)

2.3 Coefficient of Thermal Expansion:

No data available

2.4 Operating Temperature Range:

Maximum continuous operating temperature is 232°C (450°F).

3.0 Fire Behavior

3.1 Surface Burning Characteristics:

Fiberglas AF530 is inherently fire safe. ULC Flame Spread rating of 15. (compared to untreated Red Oak as 100 - test method ULC S-102)

4.0 Durability:

No changes should occur to the insulation when subjected to chemicals normally encountered in use conditions. No thermal degradation has been found after prolonged stagnation testing. Moisture adsorption is less than 0.2% by volume, 96 hours at 49°C (120°F) and 95% R.H. Inorganic therefore does not breed or promote bacteria and fungus. Essentially odorless.

E. Collector Assembly

1.0 General Description:

The collector is assembled in four stages. First, the collector frame and backing sheet are assembled. Second, the back and side insulation are installed, third, the tested absorber assembly is inserted, and finally, the glazing, seal and cap are installed.

1.1 Container:

The container consists of sections of aluminum extrusion assembled into a rectangular frame, with an aluminum backing sheet fitted into slots and pop-rieveted in place.

1.2 Insulation:

Insulation is placed on the aluminum back and along the sides.

1.3 Absorber Assembly:

The serpentine absorber is fitted into the inlet and outlet connection fittings protruding through the side. Mechanical compression fittings are inserted into EPDM grommets, locking the absorber in place and insulating it from the container. The absorber expands and contracts freely within the container.



Nova Scotia's EnviroHome,
Bedford, Nova Scotia, Canada

- one S32A solar collector
- one S32B solar collector

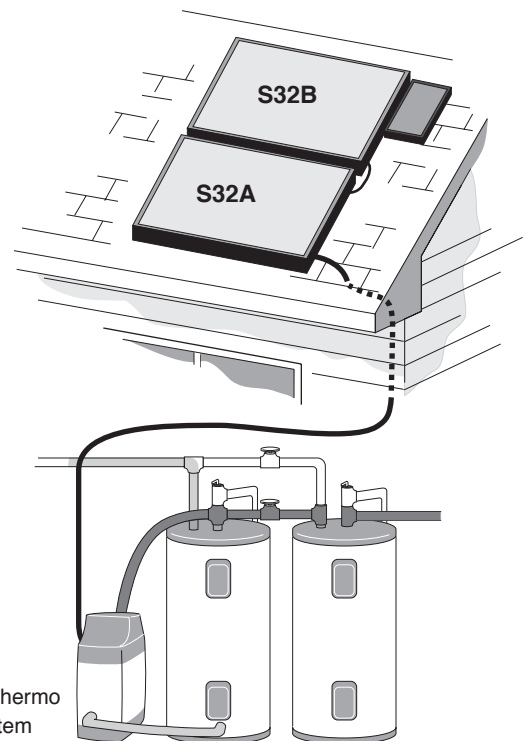

S32 solar collectors

- collectors shown as part of the Thermo Dynamics Ltd Solar Boiler™ system

S SERIES Solar Collectors

Glazed Liquid Flat Plate Collectors

Technical Specifications

SRCC Certification # 100-2009-007A



Thermo Dynamics Ltd.

101 Frazee Avenue

Dartmouth, Nova Scotia

Canada, B3B-1Z4

Tel: (902) 468-1001 Fax: (902) 468-1002

Email: solarinfo@thermo-dynamics.com

www.thermo-dynamics.com

1.4 Glazing Assembly:

The pre-cut glass is cleaned and fitted onto the retainer ledge in the collector container with a high-temperature continuous EPDM gasket. A removable aluminum cap stripping is then secured to the container with black oxide coated stainless steel screws.

2.0 Collector Container:

Collector container sides are fabricated from aluminum extrusions with an integral mounting channel. The bottom is an aluminum sheet which fits into a slot in the frame and is pop-riveted to the sides.

2.1 Materials:

Extruded framework is aluminum 6061-T6 alloy. The back sheet is aluminum utility grade sheet with a thickness of 0.51 mm (.020")

2.2 Finish:

Aluminum frame comes in a standard dark brown baked enamel finish.

3.0 Moisture Control System:

Four holes in the back sheet allow sufficient air flow through the collector to remove any condensation or moisture.

4.0 Sealant and Gaskets

4.1 General Description:

Inlet and outlet pipes are sealed with high-temperature round EPDM gaskets. The continuous glazing gasket is a U-shaped EPDM neoprene. Silicone caulking is used for the container corner sealant.

4.2 Chemical Composition:

Header and glazing gasket: ethylene propylene diene monomer rubber (EPDM)
Caulking: silicone rubber

4.3 Physical Properties:

EPDM gasket has a tensile strength of 13800 kPa (2000 psi). Sealants and gaskets do not corrode other collector materials.

4.4 Coefficient of Thermal Expansion:

no data available.

4.5 Operating Ranges:

no data available.

Sunstrip™ MICRO-FLO® absorber

typical series connection:

- S32 A collector c/w 4 connection (inlet, outlet, bypass tube)
- S32B collector c/w 2 connections (inlet, outlet)

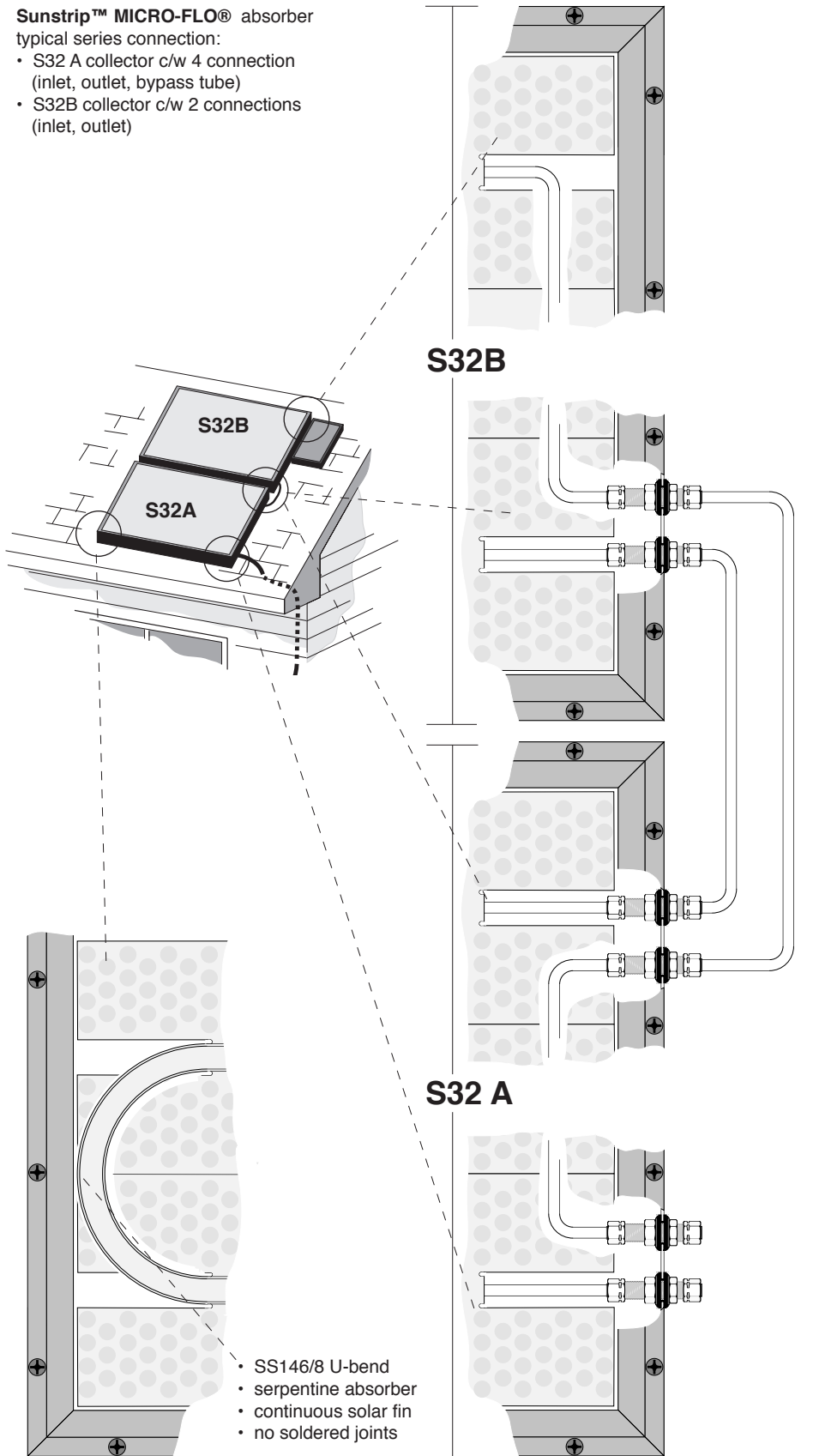

S SERIES Solar Collectors

Glazed Liquid Flat Plate Collectors

Technical Specifications

SRCC Certification # 100-2009-007A

F. Installation

1.0 Handling and Transportation

1.1 Packaging:

Collectors are shipped individually in double-strength cardboard boxes.

1.2 Labour and Equipment:

Two people can move and mount collectors.

2.0 Mounting Procedure:

An aluminum mounting bracket allows attachment to the bolt-track in the collector frame extrusion anywhere along its width or length. The mounting bracket allows collector mounting parallel to the roof surface or tilted up at any angle.

3.0 Collector Interconnection:

Small insulated copper tubing with mechanical compression fittings are used to interconnect the S Series solar collectors.

4.0 System Connection:

Piping connections are made with 3/8" diameter copper tubing with mechanical compression or sweated soldered fittings.

5.0 Start-up Tests:

- i) Air or water pressure test.
- ii) Visual check for leaks.

G. Operation

1.0 Method of operation and Control:

Collectors can be used with distilled water or antifreeze solutions. The S Series collectors operate in a closed or open-loop system. The small diameter absorber tubing does not allow for sufficient draining and should not be used in cold climate drain back/down systems.

2.0 Pressure Drop vs. Collector Flow:

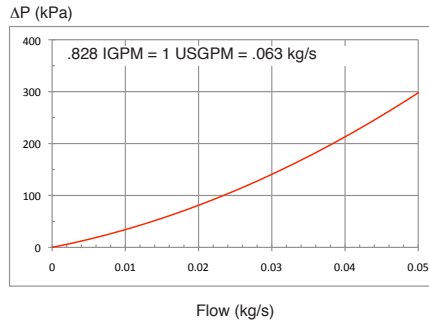

2.1 Testing Information:

Agency: National Solar Test Facility
Date: July 15, 1992
Fluid: 60% distilled water, 40% propylene glycol

3.0 Recommended Flow Rate:

1.2 L/min (0.264 IGPM)

4.0 Maximum Operating Pressure:

Factory tested to 1724 kPa (250 psi).

5.0 Recommended Operating Pressure:

Below 200 kPa (30 psi).

6.0 Maximum Operating Temperature:

200°C (392°F)

7.0 Stagnation Temperature:

Stagnation temperature of the collector is approximately 170°C (338°F).

8.0 Recommended Heat Transfer Fluids:

Propylene Glycol USP, food grade antifreeze solution for closed loop systems where freezing is a concern. The use of inhibited glycols is not recommended. **DO NOT** use ethylene glycol.

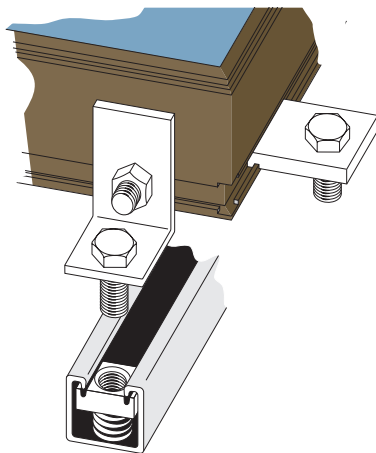

Recommended solar collector mounting methods

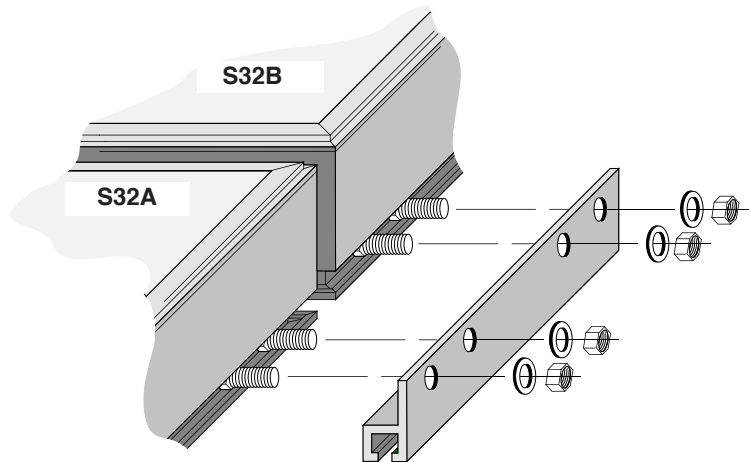

Typical inter collector mounting procedure

S SERIES Solar Collectors

Glazed Liquid Flat Plate Collectors

Technical Specifications

SRCC Certification # 100-2009-007A



Thermo Dynamics Ltd.

101 Frazee Avenue

Dartmouth, Nova Scotia

Canada, B3B-1Z4

Tel: (902) 468-1001 Fax: (902) 468-1002

Email: solarinfo@thermo-dynamics.com

www.thermo-dynamics.com

H. Maintenance and Warranty

1.0 Cleaning and Maintenance:

Glazing should be self-cleaning, depending on local conditions. Dirt accumulation on the glass cover will be washed away by the rain. If cleaning is required, use a standard window cleaning agent. The glycol antifreeze solution should be checked annually and renewed if necessary. No other maintenance is normally required.

2.0 Manufacturer Servicing:

A trouble-shooting guide to help the homeowner maintain and service the equipment is included in the installation manual. All service and repair is readily available from the manufacturer or distributor.

3.0 Availability of Parts:

All parts are available from the manufacturer and distributors.

4.0 Replacement of Parts:

The glazing may be replaced in the installed system without removing the collector from the array by removing the screws holding the glazing cap stripping. Total replacement time is a maximum of fifteen minutes and requires only a screw driver. Sensors are clamped on outlet piping using screw-type pipe clamps. Replacement time is approximately ten minutes.

If the recommended installation procedures are followed, one collector may be replaced in the array without removing another collector. Collectors are connected together with a standard copper couplings (mechanical or soldered).

5.0 Warranty:

The solar collector absorber is warranted for a period of ten years. Repair allowances may also apply. The manufacturer may repair or replace the absorber as required at his discretion.

I. Durability

1.0 Operating Experience:

The S32 has been installed worldwide since 1985.

2.0 Accelerated Aging Tests:

The collector has been subjected to 30 day plus high temperature (204°C;400°F) stagnation tests at the Canadian National Solar Test Facility with no evidence of deterioration (CSA F-378). One year of stagnation at DSET laboratories in Arizona were also conducted in 1982 with no sign of deterioration.



S32 solar collectors

- one S32A and one S32B
- integrated with Solar Boiler™ module
- total collector area: 6 m² (32 ft²)
- residential domestic hot water
- location: Nairobi, Kenya, Africa

S32 solar collectors

- one S32A and one S32B
- integrated with Solar Boiler™ module
- total collector area: 6 m² (32 ft²)
- residential domestic hot water
- location: Halifax, Nova Scotia,



S SERIES Solar Collectors

Glazed Liquid Flat Plate Collectors

Technical Specifications

SRCC Certification # 100-2009-007A

J. Collector Efficiency

1.0 General Description

1.1 Test Method:

Tested in accordance with CAN/CSA-F378-87 Standard "Solar Collectors".

1.2 Testing Information:

Agency: National Solar Test Facility
Location: Ontario, Canada

Lat. 43.53 °N

Long. 79.66 °W

Elevation: 160 m (525 ft)

Date: June 06, 2008

1.3 Details of Tested collector:

Model: S32-P

Glazing: low-iron tempered Solite

Absorber material: aluminum fin and tube

Absorber coating: SOLEC paint

Insulation: fiberglass

Gross area: 2.976 m² (32.03 ft²)

Aperture area: 2.783 m² (29.96 ft²)

Absorber area: 2.87 m² (30.9 ft²)

1.4 Comments:

The time constant, thermal efficiency test, and Incident angle modifier were determined in the solar simulator.

2.0 Test Conditions

2.1 Collector Tilt and Orientation:

Normal to the direction of irradiation.

2.2 Heat Transfer Fluid:

Water

2.3 Liquid Flow Rate:

0.020 kg/s (0.044 lb/s)

2.4 Mean Ambient Air Temperature:

25.1°C (77.2°F)

2.5 Wind Velocity:

3.1 m/sec (10.2 ft/sec)

2.6 Insolation:

908 W/m²

288 Btu/ft² h

3.0 Time Constant:

115sec ± 5 sec at 0.021 kg/s (0.46 lb/s)

4.0 Efficiency:

Based on gross collector.

First order efficiency equation:

$$\eta = 0.694 - 4.809(T_i - T_a)/G$$

5.0 Incident Angle Modifier:

$$K_{(inc)} = 1 - 0.25(1/\cos\theta - 1)$$

6.0 SRCC Standard Day Tests:

The following standard day tests were performed by the Solar Rating & Certification Corporation, (SRCC).

SRCC Standard Day Tests, (SRCC Standard 100-81)

Megajoules Per Panel Per Day				Thousands of Btu Per Panel Per Day			
Category (T _i - T _a)	Clear Day 23 MJ/m ² •d	Mildly Cloudy 17 MJ/m ² •d	Cloudy Day 11 MJ/m ² •d	Category (T _i - T _a)	Clear Day 2000 Btu/ft ² •d	Mildly Cloudy 1500 Btu/ft ² •d	Cloudy Day 1000 Btu/ft ² •d
A (-5°C)	42.7	32.3	22.0	A (-9°F)	40.5	30.6	20.8
B (5°C)	38.3	27.9	17.5	B (9°F)	36.3	26.4	16.6
C (20°C)	31.6	21.4	11.2	C (36°F)	29.9	20.2	10.6
D (50°C)	18.5	9.3	1.6	D (90°F)	17.5	8.8	1.5
E (80°C)	7.1	0.8		E (144°F)	6.7	0.8	

Incident Angle Modifier

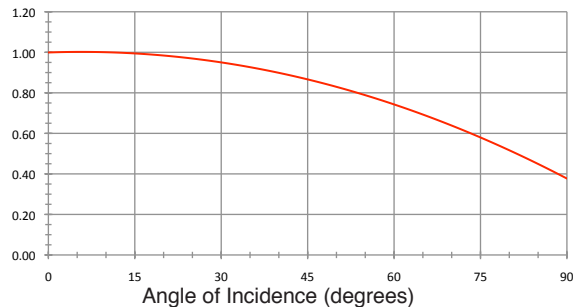

Collector Thermal Efficiency

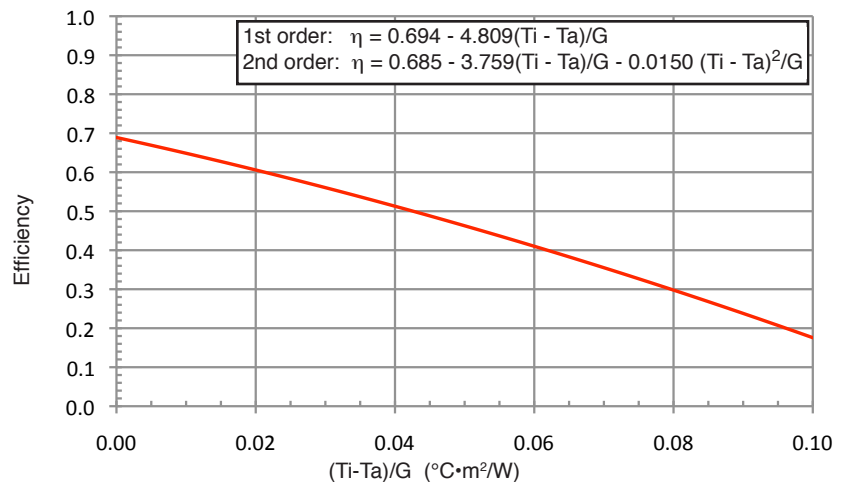

The S Series Collectors described by this brochure, when properly installed and maintained, meet the minimum standards established by the SRCC, (Solar Rating & Certification Corporation). This certification does not imply endorsement or warranty of this product by SRCC.



SOLAR RATING AND CERTIFICATION CORPORATION

Independent Certification of Solar Water and Swimming Pool Heating Collectors and Systems

