

S E N S I B L E

E C O L O G I C A L

E C O N O M I C A L

A F F O R D A B L E

S E N S I B L E

E C O L O G I C A L

E C O N O M I C A L

A F F O R D A B L E

S E N S I B L E

E C O L O G I C A L

E C O N O M I C A L

A F F O R D A B L E

S E N S I B L E

E C O L O G I C A L

E C O N O M I C A L

A F F O R D A B L E

S E N S I B L E

Angle	H/L	Rise	Run
14°	0.24	0.10	0.42
18°	0.31	0.13	0.52
23°	0.40	0.17	0.67
27°	0.50	0.22	0.87
34°	0.67	0.29	1.12
45°	1.00	0.41	1.67

E C O L O G I C A L

E C O N O M I C A L

A F F O R D A B L E

S E N S I B L E

E C O L O G I C A L

E C O N O M I C A L

A F F O R D A B L E

S E N S I B L E

# Solar Boiler™

## INSTALLATION MANUAL FOR MODELS: SB32-9PV AND SB64-9PV

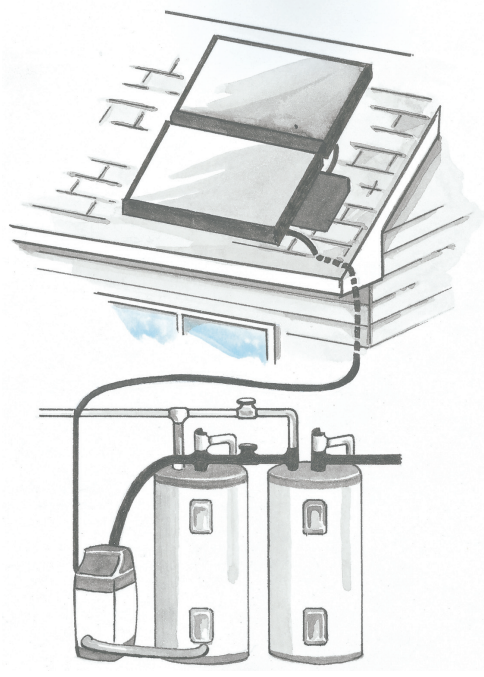

**WARNING**

The approved heat transfer fluid is 40% Propylene Glycol USP and 60% distilled water. The substitution of any other heat transfer fluid can cause irreparable damage and create a health and safety hazard.

The Solar Boiler™ module contains 3.75 liters (1 US gallon) of heat transfer fluid when full.

The installation of the Solar Boiler™ system should be installed by a qualified technician.

Assemblies and materials shall meet requirements of the applicable codes and Standards for fire safety.

# Solar Boiler™

## SB32-9PV and SB64-9PV Solar Boiler™ System Components

Congratulations on the purchase on your new Solar Boiler™ system by Thermo Dynamics Ltd. The Solar Boiler™ is the newest and most advanced concept in residential solar domestic water heating systems.

This manual outlines all of the steps necessary for a quick trouble free installation. Read the entire manual carefully before any installation attempt is made.

Be sure to follow all local codes when installing the Solar boiler system.



**Solar Collectors  
S Series (Micro-Flo®)**



**Solar Boiler™ module**

A 270 liter, (60 IG) Storage tank is required for the installation and is not included. **In Canada, the tank must be CSA approved and all plumbing fittings must comply with CSA B.125**

Quantity	System	Model	Description
1	SB64-9PV only	S32A-P	4' x 8' S Series Serpentine Collector, "A", 4 ports
1	SB32-9PV SB64-9PV	S32B-P	4' x 8' S Series Serpentine Collector, "B", 2 ports
1	SB32-9PV SB64-9PV	SBM13DC	Solar Boiler Module - Solar Pump (complete with Delta-T Booster II and temp sensors) - Heat Exchanger - Expansion Tank - Glycol Reservoir (Complete with 4 liters of glycol) - Glycol inlet/outlet ports - Water inlet/outlet ports
1	SB32-9PV SB64-9PV	PV20	Photovoltaic Module, 20 Watt
1	SB32-9PV only	K1050	Serpentine Collector Mounting Kit (for 1 S Series - mounts flush to roof)
1	SB64 9PV only	K1055	Serpentine Collector Mounting Kit (for 2 S Series - mounts flush to roof)
1	SB32-9PV SB64-9PV	K1060	Photovoltaic mounting kit (mounts to Serpentine Collector)
1	SB32-9PV SB64-9PV	K2030-50	Copper Tube Kit (3/8" Copper tube, 2 x 50 ft, Insulation, 100 ft, 18/4 LVT wire, 60 ft
1	SB32-9PV SB64-9PV	GLYUSM	Propylene Glycol USP, (mixed 40% glycol 60% water), 4 liters
1	SB32-9PV SB64-9PV		Tank Connection Fittings, (Brass)

# Installation Manual for SB32-9PV and SB64-9PV

## How the Solar Boiler™ Works

- Solar collectors absorb sunlight and convert it to heat.
- When there is sufficient sunlight, the photovoltaic module produces electricity and turns the pump.
- The pump circulates heat transfer fluid, (HTF), through the solar collectors.
- Heat is transferred to the HTF in the solar collector.
- The HTF is returned to the heat exchanger in the Solar Boiler™ module.
- The heat is transferred to the water which circulates naturally to the top of the solar storage tank.
- Solar heated water is stored in the solar storage tank until water is drawn from the auxiliary tank (in this case an electric water heater).
- As hot water is drawn from the electric water heater it is replaced with solar heated water.
- The electric heaters increase the temperature of the solar heated water, if necessary.
- The electrical energy required to heat water is significantly less when water is preheated by the solar water heater.
- In this manner, the solar water heater saves electrical energy.

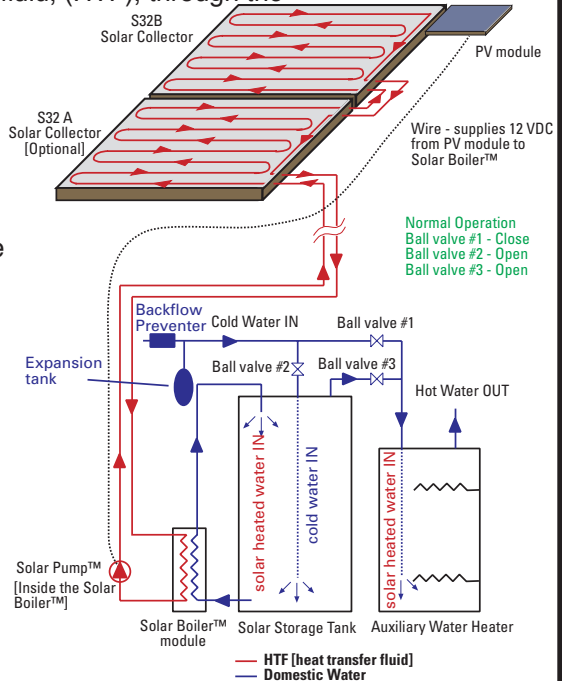

### NOTE:

The Solar Boiler™ is designed to shut off when a temperature of 70°C (158°F) is attained in the solar storage tank.

The heat transfer fluid is a 40/60 % by volume mixture of Propylene Glycol USP and distilled water. The Solar Boiler™ module contains 3.75 liters (1 US gallon) of heat transfer fluid. An additional 3.75 liters (1 US gallon) is supplied with the system for filling the system during start up.

The maximum safe working pressure of the heat transfer fluid is 60 psi, (410 kPa).

The Solar Boiler™ system is inherently grounded through copper piping connected to the main water supply. Ensure that household ground is adequately electrically grounded.

# Solar Boiler™

## System and Installer Details

Installer	
Address	
Tel:	
Fax	
Email:	

System Details	
Solar Boiler Model	
Solar Collector Serial#(s)	
Solar Boiler Serial#	
Storage Tank Serial#	
Orientation E or W of South	
Collector Slope	
Collector Mount (Flush or Inclined)	

**IMPORTANT:** CSA requires a back flow preventer between the household domestic water distribution system and the inlet to the solar domestic hot water system.

**A potable water expansion tank MUST be installed on the solar domestic hot water system.**

# Installation Manual for SB32-9PV and SB64-9PV

## Solar Collector Location

Micro-Flo® solar collectors are designed to work with the Solar Boiler™ module and other Micro-Flo® systems.

Locate the solar collectors on the roof of your home that is oriented true south or as close as possible. There are no major losses up to 45° east or west of true south. If your orientation is not in this range, consider a ground mounting system. The solar collectors are to be installed such that they are not shaded for at least 5-6 hours during the middle of the day.

The recommended slope is equal to the local latitude plus or minus 10°. For example, Halifax, Nova Scotia is at a latitude of 45°. Therefore the recommended collector slope for a home located in or near Halifax is between 35° and 55°. For effective snow removal in the winter a slope of at least 45° is recommended.

To calculate the slope of your roof, measure the dimensions “H” and “L” as shown in the figure. Calculate the quantity H/L and compare it to the table to determine if an inclined mount is required.

### Inclined Mount

The inclined mounting kit allows the collectors to pivot in the front and uses aluminum channel to support the solar collector at the rear. Instructions are provided with the rack mount kit.

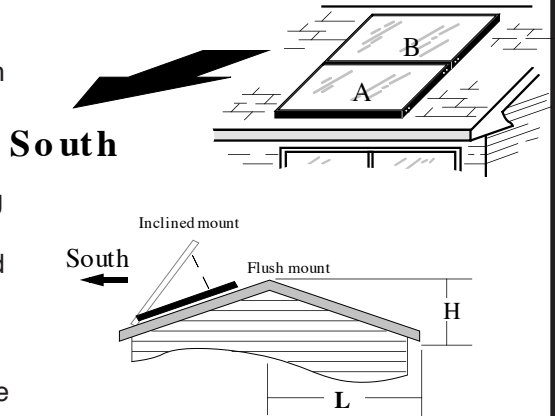

Angle	H/L	Rise/Run
14°	0.25	3/12
18°	0.33	4/12
23°	0.42	5/12
27°	0.50	6/12
34°	0.67	8/12
45°	1.0	12/12

# Solar Boiler™

## 1 – Locating Roof Rafters

Locate the rafters directly under the solar collectors, and at least 8" from the ends of the solar collectors. In the case of 4' x 8' solar collectors and 24" rafter spacing, the clips should be mounted six feet apart (that is, one foot from the edge of the collector).

To find the center of the rafters, lift the shingle and use small nails to find the two edges of the rafter.

Drill a 1/4" pilot hole in the rafter for each of the front mounting clips.

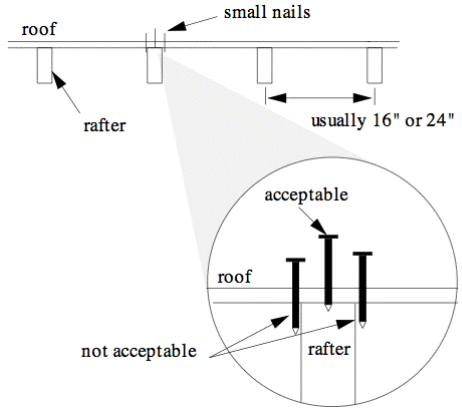

## 2 – Flush Mounting Micro-Flo® Solar Collectors

Fill the holes with silicon sealant and secure the two front clips to the roof using lag bolts. Seal the perimeter of each mounting clip base with silicon.

Take the "A" solar collector and slide two 3/8" bolts in the bolt track.

Loosely fasten these bolts to the bottom hole of the front mounting clips using a lock washer and nut.

Center the solar collector so that the spacing from the end of the solar collector to the mounting clip is equal on both ends. The solar collector ports must be on the right hand corner of the solar collector when, viewed from below.

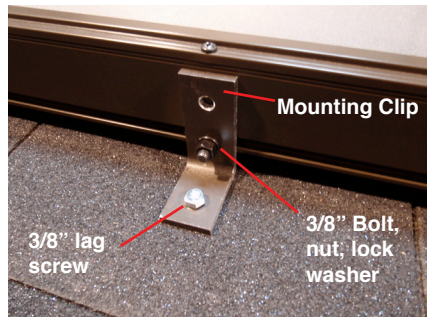

# Installation Manual for SB32-9PV and SB64-9PV

## 3 – Optional Second Solar Collector

If you have a two solar collector system, place the B solar collector above the A solar collector. Make sure that the ports are on the right hand side.

Using the aluminum channel, fasten collector B to A as shown in the figure.

Fasten the upper mounting clips (not shown) to the top of the collector(s), and use lag bolts to secure them to the rafters in the same manner as for solar collector A.

Tighten all nuts that secure the collector(s) to the mounting clips.

Silicon seal all roof attachments.

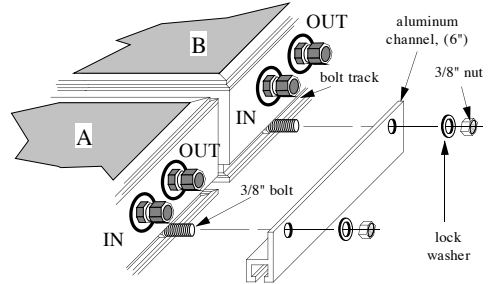

## 4 – Copper Tube Kit Installation

The copper tube kit is used to connect the Solar Boiler™ module to the solar collectors.

All of the copper tubing should be sleeved with the insulation provided. The insulation is Elastomeric Expanded Closed Cell with a 0.5" thickness. Mark one copper tube at both ends with tape to identify the supply and return lines.

Run the copper tube and wire to the solar collectors via an unused space or closet. If the bundle is run outside along the house, sleeve it in a plastic conduit such as down spout. Note: All copper tube installed in the horizontal position must slope down 1/4" for every horizontal foot. Secure the Copper tube at intervals of 6 feet with clamps. Use caution when bending the tube to avoid kinking.

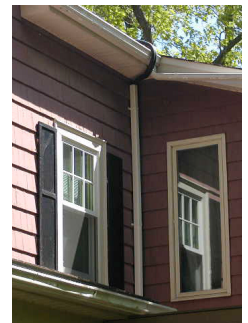
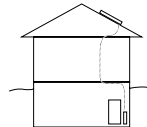
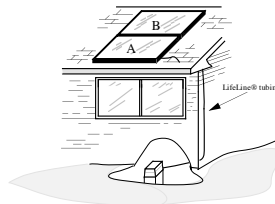

# Solar Boiler™

## 5 – Copper Tube at Solar Collectors

The copper tube roof penetration is made adjacent to the "A" collector for the SB64-9PV system and the "B" collector for a SB32-9PV system.

Make a roof penetration at a position 8" - 10" horizontally away from the "A", ("B") collector bottom ports. A 3/8" hole for each tube and the wire is sufficient.

Pass about 2 feet of Copper tube through the roof penetration from below. Clamp the copper tube to the truss. Do not crimp the copper tube.

Seal the roof penetration with silicon sealant.

If the copper tube has been installed on the outside of the house, a roof penetration is not necessary. Simply bend the tubing bundle around the soffit and up to the solar collectors



## 6 – Copper Tube Connection to Collector

Connect the 3/8" copper tube to the "IN" (blue) port using a 5/8" and 11/16" wrench. Be sure to hold the bulkhead union from moving during this process. Connect the other 3/8" copper tube to the "OUT" (red) port.

**IMPORTANT:** The 11/16" wrench is required to prevent the bulkhead union from rotating while turning the nut with the 5/8" wrench.

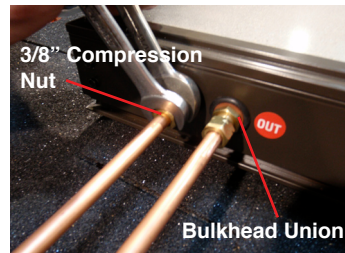
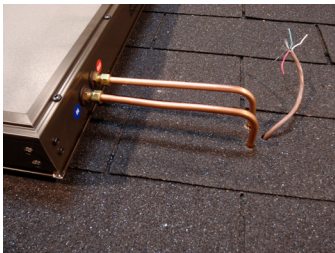



# Installation Manual for SB32-9PV and SB64-9PV

## 7 – Connection Between Collector A and B

Place the 3/8" compression nuts on the fitting body finger tight.

Insert the copper tubes into the ports as shown, until they bottom out.

Using a 5/8" and a 11/16" wrench, tighten the nuts one full turn.

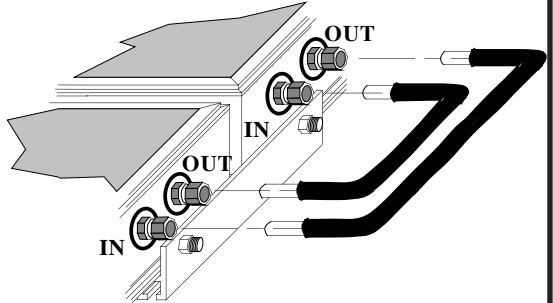

**IMPORTANT:** The 11/16" wrench is required to prevent the fitting body from rotating while turning the nut with the 5/8" wrench.

## 8 – Preparing the Photovoltaic Module

Attach the two large aluminum brackets to the photovoltaic module using the 3/8" bolts, nuts, and lock washers supplied. Make sure that the junction box on the back of the PV panel is at the top.

Make sure both aluminum angle brackets are securely fastened to the photovoltaic module.

**Grounding:** The photovoltaic module is inherently grounded through the mounting hardware attached to the solar collectors.

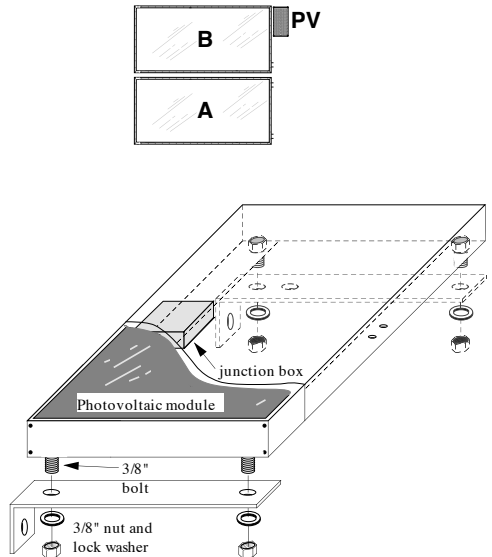

# Solar Boiler™

## 9 – Wiring the Photovoltaic Module and Collector Sensor

Open the junction box located on the photovoltaic module, and note the positive terminal marked "+" and the negative terminal marked "-".

Drill 2 small holes and insert the 18/4 LVT wire in the box. Connect the "RED" to "+" terminal and the "BLACK" to "-" terminal.

Feed the white and green wires out of the junction box and connect them to the collector sensor using pinch connectors supplied.

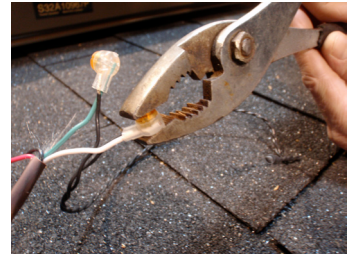
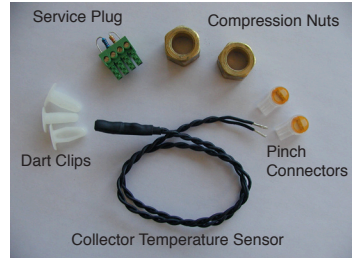

## 10 – Locating the Photovoltaic Module

Locate the photovoltaic module as shown in the diagram, along the port side of the "B" collector. Using the 3/8" bolts, washer, and nuts, attach the photovoltaic module to the "B" collector bolt track as shown in the diagram. **Ensure that all the nuts are tightened securely in order to provide proper grounding of the PV module.**

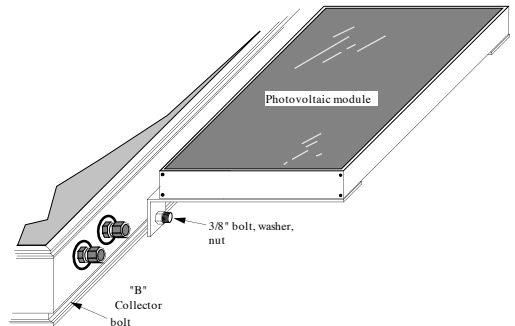

Insert the temperature sensor into the "B" collector. It should go in about 6 to 8 inches. Seal with silicon.

Using the connectors provided, crimp the sensor wires to the green and white wires.

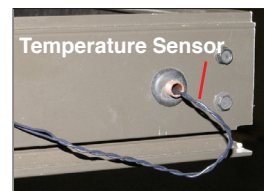

# Installation Manual for SB32-9PV and SB64-9PV

## 11 – Setting Up the Solar Boiler™ Module, (Bottom Connections)

Place the Solar Boiler™ module and solar storage tank next to your auxiliary water heater.

Remove the drain valve from the solar storage tank. Install the bottom tank assembly. Position the tee such that one end points toward the Solar Boiler™.

Apply teflon tape to the hose bib and attach it to the end of the tee that is pointing away from the Solar Boiler™.

Connect the tee to the Solar Boiler™ module using 3/4" copper pipe.

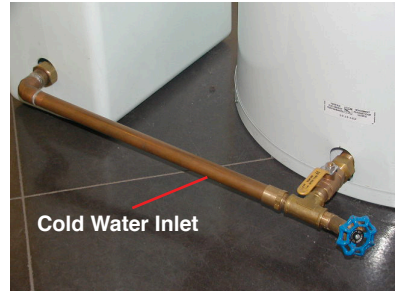

## 12 – Setting Up the Solar Boiler™ Module, (Top Connections)

Connect the top outlet of the Solar Boiler™ module to the top tank Temperature Pressure Relief Valve, (TPRV), port using 3/4" copper pipe and the 3/4" vented 90° elbow supplied.

Wrap teflon tape around the short nipple of the top tank tee, and thread it into the “hot outlet” port of the solar storage tank. This tee becomes the “hot outlet” port of the solar storage tank.

Plumb the TPRV to a drain.

*(We recommend a licensed plumber integrate the Solar Boiler™ module and solar storage tank with your existing domestic water system.)*



# Solar Boiler™

## 13 – Isolation Bypass Preparation

Close the main cold water supply valve to the existing water heater.

Install two copper tees and a ball valve #1 as shown in the diagram. Label this ball valve: BALL VALVE #1.

Insulate all hot water pipes and the 5 feet of cold pipe leading to the solar storage tank. All insulation should be Elastomeric Expanded Closed Cell with a minimum thickness of 0.5”

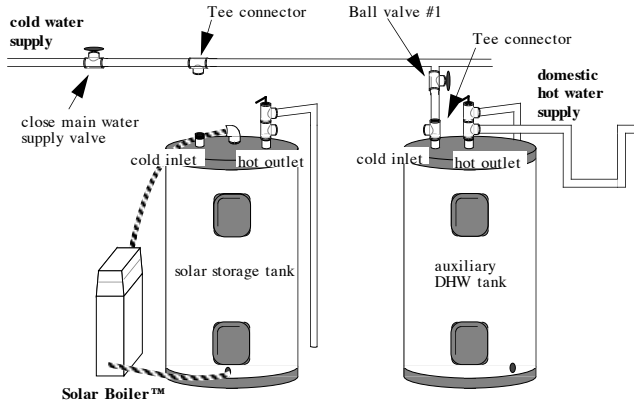

## 14 – Isolation Bypass connection

Connect the main cold water supply to the cold inlet of the solar preheat tank.

Install a ball valve in this line. Label this valve: BALL VALVE #2.

Connect the hot outlet of the solar storage tank to the cold water supply of the existing water heater. Install a ball valve in this line, and label it: BALL VALVE #3.

Install two heat traps as shown in the diagram to minimize heat loss from the solar storage tank. Please note that the domestic hot water supply line must have a mixing valve installed as shown in the diagram.

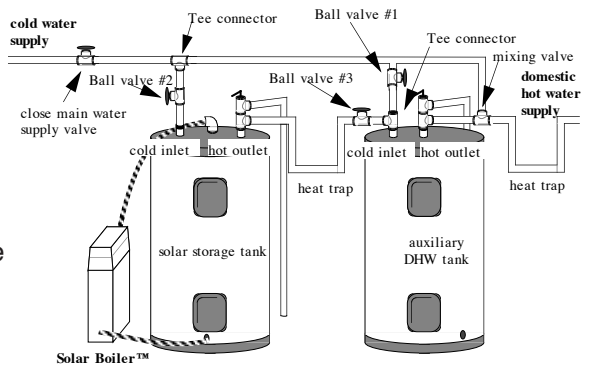

### For normal solar operation:

- Ball valve #1 - close
- Ball valve #2 - open
- Ball valve #3 - open

Insulate all hot water pipes.

For normal solar operation, the valves should be opened or closed as shown in the diagram.

# Installation Manual for SB32-9PV and SB64-9PV

## 15 – Solar Boiler™ Copper Tube Connections

The Solar Boiler™ module is prefilled with heat transfer fluid.

Carefully remove the plugs from the brass fittings and retain. Replace with the 3/8" compression nuts provided. Turn the nuts on until finger tight.

Insert the marked copper tube in the fitting located on the pump until it bottoms. Using two wrenches, one on the fitting body and one on the nut, tighten the nut one full turn.

Repeat the above procedure for the other copper tube.

**IMPORTANT:** Do not overtighten the nuts. Overtighten could cause a leaky connection and/or cracked nuts.

Ensure that the household cold water main is adequately electrically grounded



## 16 – Solar Boiler™ PV and Sensor connections

Locate the Delta-T Booster II. Ensure that the power switch is in the "OFF" position.

Connect the "WHITE" and "GREEN" sensor wires to the terminals marked "Tc".

The "Ts" terminals are for the storage sensor located in the Solar Boiler™ module and is factory installed.

Feed the "RED" and "BLACK" wires to the "PV+" and "PV-" terminals. Connect the "BLACK" wire to the "PV-" terminal. Connect the "RED" wire to the "PV+" terminal.

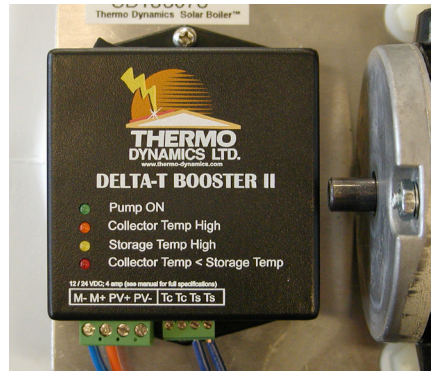

**Caution:** Never connect any other sources of electricity to the Delta -T Booster. A 12 VDC power supply may be connected directly to the motor wires, ORANGE = "+" and BLUE = "-"

# Solar Boiler™

## 17 – Filling Solar Storage Tank

Pressurize the solar storage tank by opening the main cold water supply valve and a hot water tap (near the Solar Boiler™ if possible).

As the solar storage tank fills with water, air will escape through the open hot water tap. Check for leaks.

When the solar storage tank is full, close the hot water tap.

Ensure that the solar isolation bypass valves are in the correct positions as indicated in step 14.

- Ball Valve #1 - CLOSE
- Ball Valve #2 - OPEN
- Ball Valve #3 - OPEN

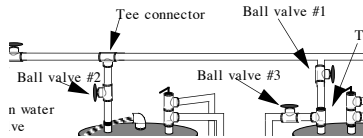

Carefully open the air vent at the top of the solar storage tank to allow air to escape from the Solar Boiler™ module.

## 18 – Solar Boiler Start Up

Remove the pressure relief valve and brass cap from the Solar Boiler module. Some fluid may be visible.

Remove the “Sensor Plug” from the Delta-T Booster II and replace it with the “Service Plug”.

Turn the switch “ON” on the Delta-T Booster II.

If there is sufficient sunlight, the pump will begin operation. Initial start up of the system should be done with sufficient sunlight to ensure proper operation.



Service Plug

Pressure Relief Valve Location

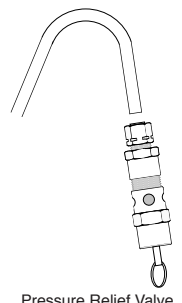

Pressure Relief Valve

**The Solar Boiler™ module contains 3.75 liters (1 USG) of HTF. An additional 3.75 liters (1 USG) is provided to top up the system. Once filled, an SB32-9PV or SB64-9PV Solar Boiler™ system contains 4 – 6 liters (1.1 – 1.6 USG) of HFT**

# Installation Manual for SB32-9PV and SB64-9PV

## 19 – Solar Boiler™ Start Up (continued)

You will hear air bubbling in the Solar Boiler unit. This is normal. Place a container under the vent tube. Using a funnel, SLOWLY pour the supplied heat transfer fluid into the Solar Boiler™ unit until fluid comes out of the vent tube. When the fluid stops coming out of the vent tube, replace the pressure relief valve and the brass cap, **remove the “Service Plug” and replace with the “Sensor Plug”.**

Check for leaks at all copper tube connections. If a leak is observed, tighten the nut 1/4 turn. Remember to use two wrenches, one on the fitting body and one on the nut.



Fill Tube

Pressure Relief Valve / vent tube

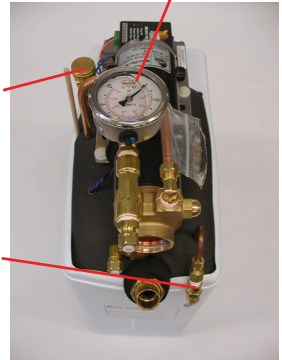

Pressure Gauge

**Caution: Never open the fill tube while the Solar Boiler is hot. Scalding fluid may spray. Always relieve the pressure in the Solar Boiler™ with the pressure relief valve before opening the fill tube.**

## 20 – Solar Boiler Normal Operation

- The Delta-T Booster II will turn ON when the Collector sensor measures 3°C higher than the Storage sensor.
- The Delta-T Booster II will turn OFF when the Collector sensor drops in temperature so that it measures 1 degree higher than the Storage sensor.
- The Storage High temperature set-point is factory set to 70°C (158°F).
- The Collector High temperature set-point is 112°C (234°F).
- The Storage Low temperature set-point is -3°C (27°F).
- There is 3°C (5.4°F) of hysteresis for all setpoints, meaning that once a setpoint has been reached, that temperature must fall by 3°C before the controller will turn ON again.



# Solar Boiler™

## 21 – Delta-T Booster II LED's

The following describes the conditions required to illuminate each particular LED: (Delta T refers to the difference in temperature between the collector temperature and the storage temperature.)

- RED: low delta T; Collector sensor open circuit.
- YELLOW: Storage temperature HIGH; Storage sensor short circuit.
- AMBER: Collector temperature HIGH; Collector sensor short circuit.
- GREEN (ON): the Collector temperature is sufficiently greater than the Storage sensor. System should be running. However, if there is insufficient sunlight, the LED may be "ON" yet the pump will not be turning.

No LEDs will be illuminated when:

- The power switch is in the OFF position,
- There is no power from the PV panel (no sunshine),
- The Storage sensor is open circuited,
- The Storage sensor measures  $-3^{\circ}\text{C}$  or less.

## Delta-T Booster II Fuses and Service Plug

The Delta T Booster II has two internal fuses, F1 and F2. Both fuses are fast acting, size 3AG.

F1 is rated at 4 A, 250 VDC and is used to protect the controller circuit.

F2 is rated at 2 A, 250 VDC and is used to protect the motor from overheating.

**Should either of these fuses need replacement, they must be replaced with an equivalent rated fuse.**

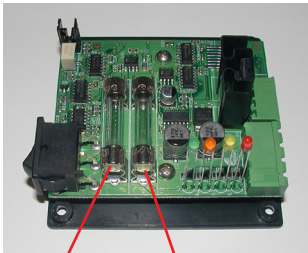

**Fuse F1 - 4 amps**

**Fuse F2 - 2 amps**

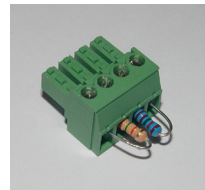

**Service Plug** - The "Service Plug" provided is used to override the Delta-T Booster II's temperature controls.

The "Service Plug" should only be used for commissioning and servicing the Solar Boiler™ System.





# Solar Boiler™

## Operating Restrictions and Maintenance

Do not use the Solar Boiler™ system to heat any treated water system, such as pools, directly.

Use the proper mixture and quantity of propylene glycol USP and distilled water for freeze protection. **DO NOT use automotive antifreeze, recreational vehicle anti-freeze, ethylene glycol, or other poisonous fluids.** Thermo Dynamics recommends a mixture of 40% Propylene Glycol USP and 60% distilled water for use as the heat transfer fluid.

**The maximum safe working pressure of the Solar Boiler™ system is 60 psi (410 kPa)**

## System Maintenance

- **Solar Collector Glass:**  
In some areas the glass plate of the collectors may require cleaning once a year with an industrial cleaning product. In areas where air pollution is severe, more frequent cleaning may be required.
- **Back Flushing the Heat Exchanger: (see page 25)**  
The Solar Boiler™ heat exchanger should be flushed with clean water ever 6 months. First, close the valve at the bottom of the solar storage tank near the 1/2" brass tee that connects the tank to the Solar Boiler™. Second, connect a hose to the drain bib at the bottom tank tee, and place the free end in a drain. Open the drain bib and allow water to flow for a few minutes. This will remove residue from the Solar Boiler™ heat exchanger.
- **Reservoir Fluid Level:**  
The fluid level in the Solar Boiler™ reservoir should be checked every year. Instructions for this procedure are part of the refilling instructions. (see page 22)
- **Heat Transfer Fluid (HTF):**  
The HTF should checked annually. If the HTF is very dark in colour and has a strong odour, it should be replaced. The extracted HTF should be disposed of at your local Environmental Disposal Depot.

The pH and freeze protection capability of the HTF should be checked annually. The pH should not be less than 6. Contact your installer or Thermo Dynamics Ltd.

With proper system operation and maintenance, the HTF should last between 4 and 15 years without replacement.

# Installation Manual for SB32-9PV and SB64-9PV

## Repairs and Energy Saving Tips

If any of the components of the Solar Boiler™ or Micro-Flo® solar collectors are damaged, your local dealer or Thermo Dynamics Ltd. should be advised before any repair is attempted.

In the case of broken glass, we recommend the use of an industrial vacuum cleaner to remove all glass fragments from the collector and surrounding area. Cover the collector with a sheet of plywood to protect the absorber plate until a replacement glazing is obtained. Disconnect the wires from the photovoltaic module to the Solar Boiler™ and contact your local dealer or Thermo Dynamics Ltd.

The Solar Boiler™ should be repaired by a qualified solar technician. In some cases it may be necessary to disconnect the Solar Boiler™ for factory repair. Your local solar dealer or Thermo Dynamics should be notified before you attempt disconnection.

## Energy Saving Tips

There are several ways to increase the performance of your Solar Boiler™ and to reduce hot water heating costs. Here are a few tips on getting the most from your water heating system.

- Add an insulating blanket to your electric water heater.\*
- Add an insulating blanket to your solar storage tank.\*
- Install low flow shower heads.
- Use warm water instead of hot when washing clothes.
- Insulate exposed hot water pipe where possible.\*
- Minimize hot water use on overcast days.
- Use solar heated water as it is collected. If possible, postpone consumption of hot water to mid-morning or noon on a sunny day.
- Lower the thermostat setting of your electric water heater from 60°C (140°F) to 50°C (122°F). This should only be done by a qualified technician.

\* Available from Thermo Dynamics Ltd.

Insulating tank blankets should be minimum 2" fibre-glass with foil backing. Exposed water pipes should be insulated with minimum 0.5" Elastomeric Expanded Closed Cell insulation.

## Troubleshooting Guide

PROBLEM	COMPONENT	CAUSE	ACTION REQUIRED
<b>Solar Boiler™ stays "OFF"</b>	Potovoltaic Module	snow covered	- remove snow or allow to melt
		module is in the shade	- check to see if there are any removable obstructions shading the module
		loose wire connections	- check all wire connections - measure resistance to make sure that there is not an infinite resistance - measure voltage of module on a bright sunny day (approx. 17 VDC)
	Delta-T Booster II	defective	- contact dealer of Thermo Dynamics to replace Delta T Booster II
		All LED's "OFF"	- insufficient sunlight to turn pump. Wait for sufficient light, ensure there is no shadow on the PV module
		Orange LED "ON"	- solar collector too hot. Wait for collector to cool
		Amber LED "ON"	- storage tank has reached high limit.
		Red LED "ON"	- collector temperature less than storage tank temperature.
	Pump	pump is seized	- turn pump shaft to check that it is turning freely
	Motor	defective motor	- replace with new motor
	Sensors	loose wire connections	- check wire connections
		defective sensor	- measure resistance of sensors and reference chart in the back of manual. -replace sensor
<b>Fluid Leaks</b>	Solar Collectors	Copper tube connections	- use two wrenches to tighten the nut 1/4 turn
	Solar Boiler™	Copper tube connections	- use two wrenches to tighten the nut 1/4 turn
		pump housing	- replace pump. contact dealer or Thermo Dynamics Ltd. for assistance
		heat exchanger	- contact dealer or Thermo Dynamics for assistance
	Solar Storage Tank	fittings	- tank may require replacement, contact dealer or Thermo Dynamics
<b>Solar heat transfer fluid not "hot" on bright sunny day</b>	Pump/Motor	loose or defective wire connections	- have a technician repair or replace as required - remove pump to verify that motor is turning freely
	Pump	pump is seized	- turn pump shaft by hand to see that it is turning freely - have pump repaired or replaced
	Motor	defective motor	replace with new motor and reattach pump
	Pump	pump very hot and fluid cool (turning but not circulating)	-check fluid level add fluid as required (see technical note attached to installation manual) -disconnect photovoltaic module and contact dealer or Thermo Dynamics

# Installation Manual for SB32-9PV and SB64-9PV

## Troubleshooting Guide

PROBLEM	COMPONENT	CAUSE	ACTION REQUIRED
<b>No Heat Transfer to Water on bright sunny day</b>	Solar Boiler™ connections to top and bottom of solar storage tank	air trapped near top of tank connection	- open cap at top of tank connection about 1/2 turn to allow air to escape (DO NOT REMOVE CAP)
		ball valve closed on cold inlet pipe to Solar Boiler™	- open ball valve. The handle should be parallel to the valve body.
	Delta T Booster II	All LED's are "OFF"	- wait for sufficient sunlight - make sure power switch is "ON"
		Orange, Amber, or Red LED "ON"	- wait for condition to stop
	Pump/Motor	pump very hot and fluid cool	- check fluid level and add fluid as required - turn Solar Boiler™ "OFF" and contact Thermo Dynamics
<b>Pump/Motor Unusually Noisy</b>	Solar Boiler™ Cover	cover of Solar Boiler™ is resting against the motor or pump	- adjust cover
	Solar Boiler™ module	low fluid level in reservoir	- turn Solar Boiler™ OFF and wait for it to cool. Open brass cap and check fluid level with wooden dowel.

# Solar Boiler™

## Solar Boiler Heat Transfer Fluid Draining Instructions

Your Solar Boiler™ is precharged with HFT (heat transfer fluid) which is a mixture of Propylene Glycol USP and distilled water (40/60 by volume). In the event that you should have to drain and/or refill the Solar Boiler™, follow these instructions to ensure proper system operation.

### Draining the HTF (heat transfer fluid)

The HTF should never be drained during system operation. HTF should only be drained in the morning before system start up, or at least one hour after system shut down in the evening. This is to ensure that the HTF is not excessively hot.

- Remove the cover from the Solar Boiler. Turn the Solar Boiler off using the switch located on the Delta T Booster II.
- Relieve pressure by opening the pressure relief valve at the rear of the Solar Boiler™ module. **Caution: Fluid may be HOT.**
- Disconnect the 3/8" copper line from the Solar Boiler™ pump outlet. Allow any fluid from the lines to drain into a container. Leave lines disconnected. **Caution: Fluid may be HOT.**
- To drain the fluid in the Solar Boiler™ module, you will have to wait until there is enough sunlight for the system to operate. With a container under the outlet of the pump, install the "Service Plug" and turn the Solar Boiler™ ON. Keep the unit on until no liquid comes out of the pump. Turn the Solar Boiler™ OFF. Do not turn the system ON again until the Solar Boiler™ is refilled.
- The system is now drained. Connect the 3/8" copper line to the Solar Boiler™ unit. To refill the Solar Boiler™, follow the instructions listed on page 22.
- Replace the brass cap on the fill tube and hand tighten. Replace the pressure relief valve on the vent tube at the back of the Solar Boiler. Remove the "Service Plug" and reinstall the "Sensor Plug". Turn the Solar Boiler™ ON using the switch on the Delta-T Booster II, and replace the cover on the Solar Boiler™.

Brass Fill Cap

Pump Outlet



The extracted HTF should be disposed of at your local Environmental Disposal Depot.

# Installation Manual for SB32-9PV and SB64-9PV

## Solar Boiler Heat Transfer Fluid Refilling Instructions

- Remove the cover from the Solar Boiler™. Turn the Solar Boiler™ OFF using the switch located on the Delta-T Booster II.
- Locate and remove the pressure relief valve attached to the vent tube at the back of the unit. **Caution: Fluid may be HOT**
- Locate the fill tube at the side of the unit and remove the brass cap from the fill tube. **Caution: Fluid may be HOT.** Using the wooden dowel provided check the fluid level in the reservoir. This level should be about 8 - 12" on the dowel. If the level is low contact your dealer or Thermo Dynamics Ltd. before continuing.
- If the fluid level is low inspect the system for signs of leakage. Inspect all visible fittings on the Solar Boiler™ and the connections at the solar collector on the roof. Also inspect under the Solar Boiler™ case for signs of HTF on the floor. The HTF, Propylene glycol USP, is very slippery and dries very slowly and will remain on surfaces for an extended period of time.
- The recommended heat transfer fluid is a 40/60 mixture by volume of Propylene Glycol USP and distilled water. Fluid should be added to the Solar Boiler with a funnel to prevent spillage. When adding fluid, follow the steps 18 and 19 on pages 13 and 14.
- The required volume of the HTF to fully refill the system is 4 – 6 liters (1.1 – 1.6USG)

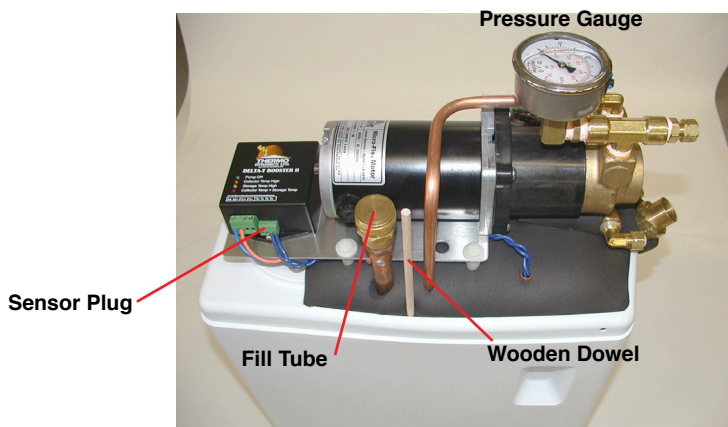

# Solar Boiler™

## Material Safety Data Sheet for Propylene Glycol USP

The HTF (heat transfer fluid) used in this Solar Boiler™ system is a mixture of Propylene Glycol, USP and distilled water (40/60)% by volume.

The following is a brief outline of the Material Safety Data Sheet for Propylene Glycol, USP. For more information, contact Univar, reference MSDS: L1173.

Product ID: NR05363  
CAS Registration #: 57-55-6  
Product Name: Propylene Glycol USP/EP  
Product Supplier: Univar  
9800 Van Horne Way  
Richmond  
British Columbia  
V6X-1W5  
Tel: 1-866-686-4827

24-Hour Emergency Telephone # (CANUTEC): (613) 996-6666

1. Ingredients:  
(% w/w, unless otherwise noted)  
Propylene glycol CAS# 000057-55-6 99.8%
2. Environmental and Disposal Information:  
Action to take for Spills/Leaks: Cover with absorbent material, soak up and sweep into bag.  
Disposal method: Incinerate or bury away from water supplies in accordance with local regulations.
3. Health Hazard Data:  
  
EYE: May cause slight transient eye irritation. Corneal injury is unlikely. Vapour or mist may cause eye irritation.  
  
SKIN CONTACT: Essentially nonirritating to skin on prolonged contact. Repeated exposure may cause slight flaking, tenderness, and softening of skin.  
  
SKIN ABSORPTION: A single prolonged skin exposure is not likely to result in absorption of harmful amounts.  
  
INGESTION: Single dose oral toxicity is extremely low. No hazards anticipated from ingestion incidental to industrial exposure.



# Installation Manual for SB32-9PV and SB64-9PV

## Material Safety Data Sheet for Propylene Glycol USP continued

**INHALATION:** A single prolonged (hours) inhalation exposure is not likely to cause adverse effects. Mist may irritate nose and throat.

**Chronic Effects of Exposure:** Repeated excessive ingestion may cause central nervous system effects.

### 4. First Aid:

**EYES:** Irrigate immediately with water for at least 5 minutes.

**SKIN:** Wash off in flowing water or shower.

**INGESTION:** No adverse effects anticipated by this route of exposure.

**INHALATION:** No adverse effects anticipated by this route of exposure.

### NOTE TO PHYSICIAN:

No specific antidote. Supportive care. Treatment based on judgement of the physician in response to reactions of the patient.

### 5. Handling and Storage:

**Handling:** Product shipped/handled hot can cause thermal burns. Product handled hot may require additional ventilation or local exhaust. Spills of these organic liquids on hot fibrous insulations may lead to lowering of the autoignition temperature possibly resulting in spontaneous combustion.

**Storage:** Store in a cool dry place. Keep away from direct sunlight or strong incandescent light. Keep containers tightly closed. Protect against moisture. Store in the following material(s): Stainless steel. Aluminum. Plasite 3066 lined container. 316 Stainless steel. Opaque HDPE plastic container. Product has a shelf life of 24 months. The maximum storage temperature is 40°C.

More information available at:

[www.univarcanada.com](http://www.univarcanada.com)

Download the full Material Safety Data Sheet # NR05363 at:

[www.thermo-dynamics.com/pdfiles/MSDS/Prop\\_Glycol\\_USP\\_EP\\_msds.pdf](http://www.thermo-dynamics.com/pdfiles/MSDS/Prop_Glycol_USP_EP_msds.pdf)

# Solar Boiler™

## Solar Boiler™ Service Log

To ensure optimum performance from your Solar Boiler™, Thermo Dynamics Ltd. recommends that the system is back flushed at least every 6 months. This service log must be kept up to date. Failure to do so will render the warranty null and void.

### Back Flushing Procedure.

- Close the valve at the bottom of the solar storage tank near the 1/2" brass tee that connects the tank to the Solar Boiler™, shown in the diagram in the diagram.
- Connect a hose to the drain bib at the bottom of the solar storage tank, and place the free end in a drain.

Open hose bib and run until water runs clear

Close hose bib and open valve at bottom of the solar storage tank.

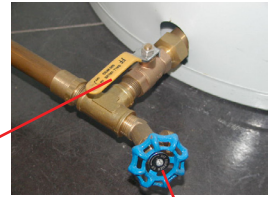

Valve (shown in OPEN position)

Hose bib

Date: _____	Technician _____	Back Flush _____
Comments _____		
Date: _____	Technician _____	Back Flush _____
Comments _____		
Date: _____	Technician _____	Back Flush _____
Comments _____		
Date: _____	Technician _____	Back Flush _____
Comments _____		
Date: _____	Technician _____	Back Flush _____
Comments _____		
Date: _____	Technician _____	Back Flush _____
Comments _____		
Date: _____	Technician _____	Back Flush _____
Comments _____		
Date: _____	Technician _____	Back Flush _____
Comments _____		
Date: _____	Technician _____	Back Flush _____
Comments _____		
Date: _____	Technician _____	Back Flush _____
Comments _____		
Date: _____	Technician _____	Back Flush _____
Comments _____		
Date: _____	Technician _____	Back Flush _____
Comments _____		

# Installation Manual for SB32-9PV and SB64-9PV

## Temperature vs Resistance Chart for 10 kohm thermistors

Measure the resistance of your collector or storage sensor and compare to the chart below. Ensure that the corresponding temperature is correct.

Replace inaccurate sensors if necessary.

<b>Temperature vs. Resistance Chart</b>		
<b>Thermistor @ 25°C</b>		
<b>°F</b>	<b>°C</b>	<b>Ohms Resistance 10K</b>
<b>OPEN</b>		<b>INFINITE</b>
32	0	32,630
41	5	25,380
50	10	19,890
59	15	15,710
68	20	12,490
77	25	10,000
86	30	8,057
95	35	6,531
104	40	5,326
113	45	4,368
122	50	3,601
131	55	2,985
140	60	2,487
149	65	2,082
158	70	1,751
176	80	1,255
194	90	917
212	100	680
<b>SHORT</b>		<b>NONE</b>



S E N S I B L E  
 E C O L O G I C A L  
 E C O N O M I C A L  
 A F F O R D A B L E  
 S E N S I B L E  
 E C O L O G I C A L  
 E C O N O M I C A L  
 A F F O R D A B L E  
 S E N S I B L E  
 E C O L O G I C A L  
 E C O N O M I C A L  
 A F F O R D A B L E  
 S E N S I B L E  
 E C O L O G I C A L  
 E C O N O M I C A L  
 A F F O R D A B L E  
 S E N S I B L E  
 E C O L O G I C A L  
 E C O N O M I C A L  
 A F F O R D A B L E  
 S E N S I B L E  
 E C O L O G I C A L  
 E C O N O M I C A L  
 A F F O R D A B L E  
 S E N S I B L E

Angle	H/L	SIN	TAN
14°	0.25	3/12	
18°	0.33	6/12	
23°	0.42	5/12	
27°	0.50	6/12	
34°	0.67	8/12	
45°	1.0	12/12	



**THERMO**  
 DYNAMICS LTD.

101 Frazee Avenue  
 Dartmouth, Nova Scotia  
 Canada B3B-1Z4

Telephone: (902) 468-1001 Facsimile: (902) 468-1002

[www.thermo-dynamics.com](http://www.thermo-dynamics.com)

[solarinfo@thermo-dynamics.com](mailto:solarinfo@thermo-dynamics.com)



243150



OG100 Certified #100-2009-007A